

DrizAir 50+ Dehumidifier

(Models: F51, F51-R)

Symbol Definition

- * - multiple components to choose from for different models: voltage, size, color, et
- + - if you order this item, you may need to order additional items marked with same number of +'s in order to upgrade or complete repair

| Find# | Part Description | Specifications/Model | Part # | Qty |
|-------|------------------------|-------------------------------|----------|----------|
| 1 | Switch | Single Rocker, Non-Lighted | 02-00012 | ea. 1 |
| 7 | Relay | DrizAir 50 | 02-00434 | ea. 1 |
| | Nylon Zip Tie | 4" | 03-00012 | ea. 4 |
| | Washer | #8-1/2" SS - Hex Hd | 03-00020 | ea. 2 |
| | Rivet | 3/16x1/4 Stl/Stl | 03-00432 | ea. 6 |
| 5 | Screw - Feet | #10-24 x 7/8 Oval SS | 03-00490 | ea. 4 |
| 6 | Nut - Feet | #10-24 SS Nylon | 03-00491 | ea. 4 |
| | Cable Tie | 11" | 03-00813 | ea. 2 |
| | Foam, Shipping Insert | (DrizAir 110 Shipping Insert) | 06-00009 | ea. 1 |
| | Insulation, Cork Tape | | 08-00784 | ft. 1' |
| | Insulation, Pipe | 3/8" x 3/8" | 08-00785 | ft. .5' |
| 12 | Hose - Gravity Drain + | (Order w/ 18-00508) | 15-00175 | ft. 2.5' |
| 2 | Fan Motor Blade | | 17-00439 | ea. 1 |
| 11 | Hose End + | (Order w/ 15-00175) | 18-00508 | ea. 1 |
| | Shrader Valve | | 18-00817 | ea. 1 |
| 4 | Defrost Control Kit | Time/Temp (Timer) | 23-00972 | ea. 1 |

DrizAir 50+ Pictorial Drawing

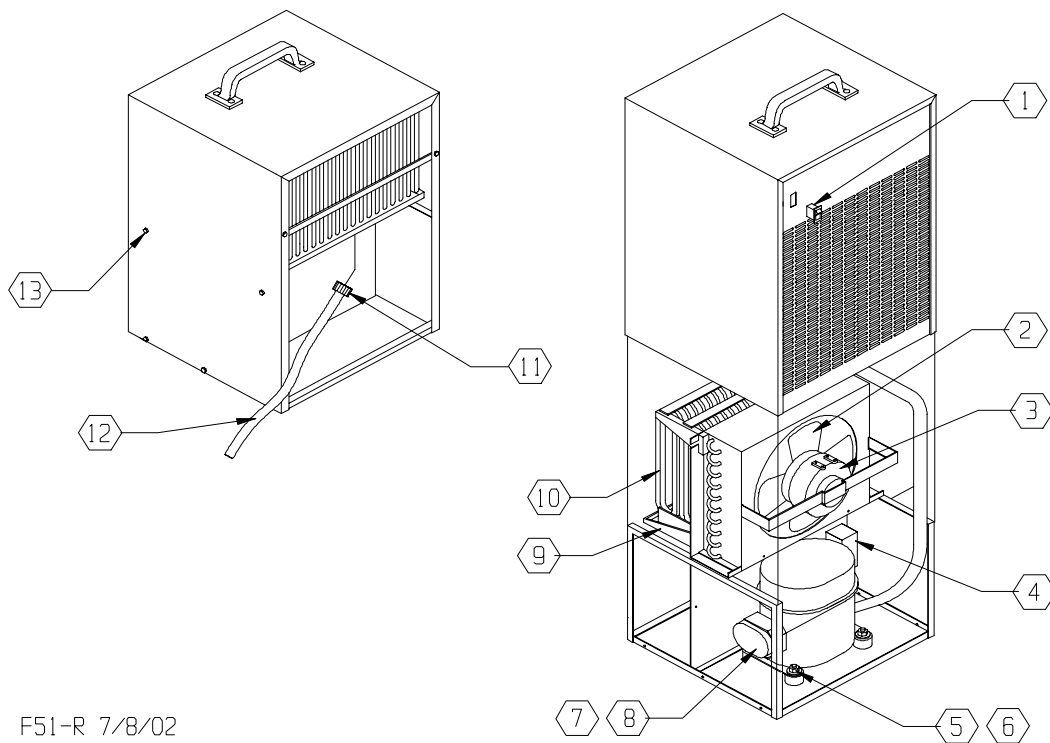

F51-R 7/8/02